



BRAIN INTERNATIONAL SCHOOL

SESSION 2024-25

CLASS: XI

TERM 1 REVISION SHEET

SUBJECT: PHYSICS

Chapter: Units and Measurement

1. Find the dimensions of a/b in the equation: $F = a\sqrt{x} + bt^2$, where F is force, x is distance and t is time.
2. Find the dimensions of a/b in the relation: $P = \frac{a-t^2}{bx}$, where P is pressure, x is distance and t is time.
3. The vander wall's equation for a gas is $(P + \frac{a}{V^2})(V - b) = RT$. Determine the dimensions of a and b . Hence write the SI units of a and b .
4. In the equation: $y = a \sin(\omega t - kx)$, t and x stand for time and distance respectively. Obtain the dimensional formula for ω and k .
5. Consider a simple pendulum, having a bob attached to a string, that oscillates under the action of the force of gravity. Suppose that the period of oscillation of the simple pendulum depends on (i) mass m of the bob (ii) length l of the pendulum and (iii) acceleration due to gravity g at the place. Derive the expression for its time period using method of dimensions.
6. The velocity ' v ' of water waves depends on the wavelength ' λ ', density of water ' ρ ' and the acceleration due to gravity ' g '. Deduce by the method of dimensions the relationship between these quantities.
7. A body of mass m is moving in a circle of radius r with angular velocity ω . Find expression for centripetal force acting on it by the method of dimensions.

CH: Motion in a straight line

1. A body starts from rest at time $t = 0$, the acceleration time graph is shown in the figure. The maximum velocity attained by the body will be

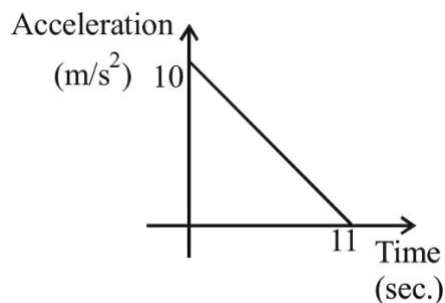

- (a) 110 m/s (b) 55 m/s (c) 650 m/s (d) 550 m/s
2. If a car at rest accelerated uniformly to a speed of 144 km/hour in 20 second it covers a distance:
(a) 400 m (b) 1440 m (c) 2880 m (d) 25 m
 3. The numerical ratio of displacement to distance is
(a) always less than 1 (b) always greater than 1
(c) always equal to 1 (d) may be less than or equal to 1

4. The distance travelled by a particle starting from rest and moving with an acceleration $\frac{4}{3}ms^{-2}$ in the third second is
 (a) $\frac{10}{3}m$ (b) $\frac{19}{3}m$ (c) 6m (d) 4m
5. A particle moves in a straight line with a constant acceleration. It changes its velocity from 10 m/s to 20 m/s while passing through a distance 135 m in t second. The value of t is
 (a) 12 (b) 9 (c) 10 (d) 1.8
6. A particle covers half of its total distance with speed v_1 and the rest half distance with speed v_2 . Its average speed during the complete journey is
 (a) $\frac{v_1+v_2}{2}$ (b) $\frac{v_1v_2}{v_1+v_2}$ (c) $\frac{2v_1v_2}{v_1+v_2}$ (d) $\frac{v_1^2v_2^2}{v_1^2+v_2^2}$
7. **Assertion:** A body may be accelerated even when it is moving uniformly.
Reason: When direction of motion of the body is changing, the body must have acceleration.
8. **Assertion:** Displacement of a body may be zero when distance travelled by it is not zero.
Reason: The displacement is the longest distance between initial and final position.
9. **Assertion:** The position-time graph of a uniform motion, in one dimension of a body cannot have negative slope.
Reason: In one – dimensional motion the position does not reverse, so it cannot have a negative slope.
10. **Assertion:** Position-time graph of a stationary object is a straight line parallel to time axis.
Reason: For a stationary object, position does not change with time.
11. **Assertion:** Velocity-time graph for an object in uniform motion along a straight path is a straight line parallel to the time axis.
Reason: In uniform motion of an object velocity increases as the square of time elapsed.
12. Using integration technique and Graphical method prove that
 (a) $v^2 - u^2 = 2as$
 (b) $s = ut + \frac{at^2}{2}$
 (c) $v = u + at$
 (d) $s_{nth} = u + \frac{a}{2}(2n - 1)$

CH: Motion in A Plane

1. $\vec{A} = 4\hat{i} + 4\hat{j} - 4\hat{k}$ and $\vec{B} = 3\hat{i} + \hat{j} + 4\hat{k}$, then angle between vectors \vec{A} and \vec{B} is
 (a) 180° (b) 90° (c) 45° (d) 0°
2. If a vector $2\hat{i} + 3\hat{j} + 8\hat{k}$ is perpendicular to the vector $4\hat{j} - 4\hat{i} + \alpha\hat{k}$, then the value of α is
 (a) 1/2 (b) -1/2 (c) 1 (d) -1
3. A projectile can have the same range 'R' for two angles of projection. If ' T_1 ' and ' T_2 ' to be time of flights in the two cases, then the product of the two time of flight is directly proportional to.
 (a) R (b) $\frac{1}{R}$ (c) $\frac{1}{R^2}$ (d) R^2
4. The maximum range of a projectile is 22 m. When it is thrown at an angle of 15° with the horizontal, its range will be-

(a) 22 m

(b) 6 m

(c) 15 m

(d) 11 m

5. A projectile is given an initial velocity of $(\hat{i} + 2\hat{j})$ m/s, where \hat{i} is along the ground and \hat{j} is along the vertical. If $g = 10 \text{ m/s}^2$, the equation of its trajectory is :
- (a) $y = x - 5x^2$ (b) $y = 2x - 5x^2$ (c) $4y = 2x - 5x^2$ (d) $4y = 2x - 25x^2$
6. State triangle law of vector addition and derive a formula for magnitude of resultant of two vectors.
7. State parallelogram law of vector addition and derive a formula for magnitude of resultant of two vectors.
8. Derive various parameters in angular projectile motion
- (a) Equation of path (trajectory)
- (b) Time of flight
- (c) Maximum height attained
- (d) Horizontal range
- (e) Velocity at any instant
9. Derive various parameters in horizontal projectile motion
- (a) Equation of path (trajectory)
- (b) Time of flight
- (c) Horizontal range
- (d) Velocity at any instant
10. Show that there are two angles of projection for which the horizontal range is same for a projectile.
11. Find the angle of projection at which the horizontal range and maximum height of a projectile are equal.
12. Derive an expression for the centripetal acceleration of a body moving in a circular path of radius ' r ' with uniform speed ' v '

CH: Laws of Motion

1. A man of mass 90 kg is standing in an elevator whose cable broke suddenly. If the elevator falls, apparent weight of the man is:
- (a) 90 N
- (b) $90g$ N
- (c) 0 N
- (d) any negative value
2. The surface is frictionless, the ratio of T_1 and T_2 is

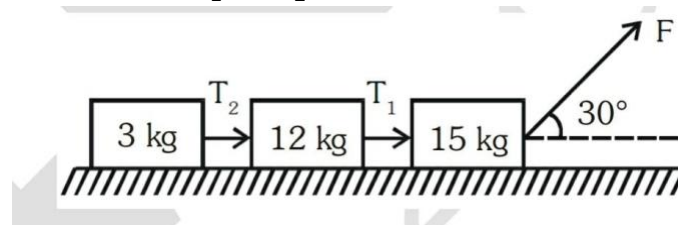

3. Show that newton's second law of motion is the real law of motion.
4. Define angle of repose and angle of friction. Establish a relation between them.
5. Derive an expression for acceleration of a body down a rough inclined plane? (Sliding only)

6. Two blocks of masses 5 kg and 10 kg are connected to a pulley as shown. What will be their acceleration if the pulley is set free? ($g = 10 \text{ ms}^{-2}$)

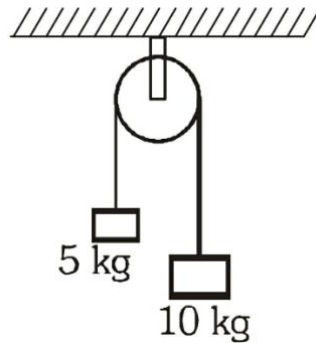

7. Explain why it is easier to pull a lawn roller than to push it.
8. Discuss the concept of apparent weight of a man in an elevator.
9. Discuss the banking of roads and railway tracks and derive a formula for safe turning on a rough banked road.
10. Why does a cyclist bend while taking a circular turn? Explain with the help of necessary calculations.

CH:6 Work, Energy and Power

- State and prove the work energy theorem for a variable force.
- What are conservative and non-conservative forces? give one example of each.
- Obtain an expression for minimum velocity of projection of a body at the lowest point for looping a vertical loop.
- Discuss elastic collision in one dimension. Derive an expression for velocities of two bodies after such a collision.
- Prove that two identical particles move at right angles to each other after elastic collision in two dimensions.
- Show that there is loss of kinetic energy during one dimensional inelastic collision.
- Derive an expression for the elastic potential energy of a stretched spring.

CH: 7 System of Particles and Rotational Motion

- The moment of the force, $\vec{F} = 4\vec{i} + 5\vec{j} - 6\vec{k}$ at $(2,0,-3)$ about the point $(2,-2,2)$, given by
 (a) $-8\vec{i} - 4\vec{j} - 7\vec{k}$ (b) $-4\vec{i} - \vec{j} - 8\vec{k}$ (c) $-7\vec{i} - 8\vec{j} - 4\vec{k}$ (d) $-7\vec{i} - 4\vec{j} - 8\vec{k}$
- A solid sphere is rotating freely about its symmetry axis in free space. The radius of the sphere is increased keeping its mass same. Which of the following physical quantities would remain constant for the sphere?
 (a) Angular velocity
 (b) Moment of inertia
 (c) Rotational kinetic energy
 (d) Angular momentum
- Derive a formula for centre of mass of a 2-particle system.
- When does a rigid body said to be in equilibrium? State the necessary condition for a body to be in equilibrium.

5. Derive the relation between angular momentum and torque.
6. Derive a formula for moment of inertia.
7. Derive an expression for the rotational kinetic energy of a body.
8. State theorem of perpendicular axes and theorem of parallel axes on moment of inertia.
9. Relation between
 - (a) torque and angular acceleration
 - (b) MOI and angular momentum
 - (c) torque and MOI
10. Obtain the expression for the linear acceleration of a cylinder rolling down an inclined plane and hence find the condition for the cylinder to roll down without slipping.
11. Prove the result that the velocity v of translation of a rolling body (like a ring, disc, cylinder or sphere) at the bottom of an inclined plane of a height h is given by

$$v^2 = \frac{2gh}{1 + \frac{k^2}{R^2}}$$

using dynamical consideration (i.e., by consideration of forces and torques). Note k is the radius of gyration of the body about its symmetry axis, and R is the radius of the body. The body starts from rest at the top of the plane.